

DC Controlled Lenses

F1,8/5,5-165mm DC Motor Zoom Lens,
1/3", CS Mount

EDP-No.: 40231

F05Z30NDDC

- Suitable for 1/2" and 1/3" Colour and B&W Cameras
- CS Mount
- DC Controlled Iris
- Without Built-in Auto Iris Amplifier
- High Standard of Optical and Mechanical Quality
- Quality Motors on Focus and Zoom
- Adjustable Slip-ring Mount for Cable Positioning



Specifications:

Focal length (f)	5.5-165 mm
Aperture range (F)	F1.8-F360
Lens mount	CS
Nominal format size	1/3"
Flange focal length	12.5 mm
Horizontal angle of view at nominal format size	47.6°-1.7°
Minimum object distance (M.O.D.)	1.8 m
Screw-in depth	4.0 mm
Filter screw size	M72x0.75 mm
Cable length	>50 cm
Slip-ring mount	340°-360° Variable adjustment range
Iris control system	Galvanometer
Connection	Cable length: 20 cm, with 4-pin DC plug
Supply voltage range	8.0 VDC +/-20%
Max. current consumption/motor (run)	25 mA
Response time	Approx. 6 sec. (at 8 V)
Motor clutch on focus/zoom	Yes
Potentiometer on focus and zoom	Available
Temperature range	-10°C to +50°C
Dimensions (HxWxD)	See drawing
Weight	850 g

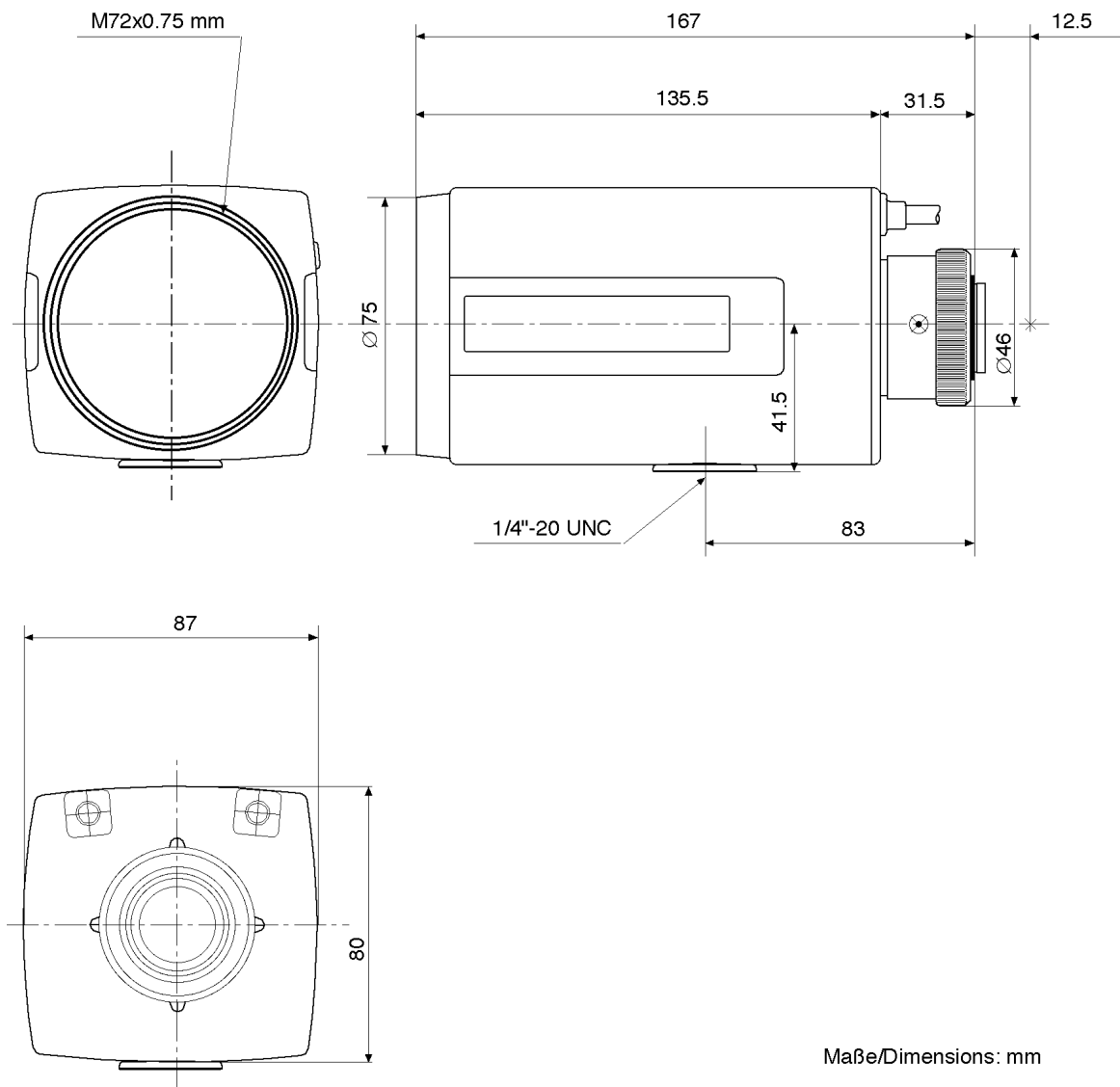

Maße/Dimensions: mm