

# VKCD-1326/IR

Home | Security | Dome Cameras | Fixed

VKCD-1326/IR

1/3" Dome, Fixed, Day&Night, tinted, 3.8-9.5mm,

550TVL, IR Illumination, 12V

**Art-Nr. 92221**



## Main Features

1/3" Super HAD Colour/B&W CCD Sensor  
Integrated F1.2/3.8-9.5mm Varifocal DC Iris Lens  
Removable IR Cut Filter  
Sensitivity of 0.2Lux at F1.2 (Colour)  
Backlight Compensation (BLC)  
Flickerless ON/OFF

Automatic Gain Control (AGC)  
Automatic White Balance (AWB)  
IR Illumination by 20 integral 850nm LEDs  
Manual 3-axis Camera Gimbal  
Supply Voltage 12VDC  
For Wall and Ceiling Surface Mount

## Specifications

System	day&night, CCIR/PAL
Sensor size	1/3"
Imager	CCD, Sony Super HAD CCD
Active picture elements	440,000, 752(H) x 582(V)
Synchronization	Internal
Signal-to-noise ratio	50dB (AGC OFF)
Sensitivity (at 50% video signal)	1.5Lux at F1.2 (colour); 0.19Lux at F1.2 (B&W)
Horizontal resolution	550 TVL
Rotation range	360°
Automatic gain control (AGC)	Automatic (On/Off switchable)
Automatic electronic shutter (ESC)	1/50 ~ 1/100,000sec.
Low Speed Shutter	yes
Low speed shutter	32fps max. On/Off switchable

# VKCD-1326/IR

(Continuation Specifications)

<b>Digital Noise Reduction (DNR)</b>	yes
<b>Flickerless function</b>	On/Off switchable
<b>White balance (AWB)</b>	Automatic control
<b>Automatic white balance (AWB)</b>	Available
<b>Backlight compensation</b>	BLC, ON/OFF switchable
<b>Wide Dynamic Range (WDR)</b>	no
<b>Aperture Correction (APC)</b>	Horizontal and vertical
<b>IR cut filter</b>	switchable
<b>Video outputs</b>	CVBS, 1Vp-p, (C)VBS, 75ohms, BNC
<b>Lens mount</b>	integrated lens
<b>Lens type</b>	varifocal
<b>Aspherical technology</b>	yes
<b>Focal length</b>	3,8 mm - 9,5 mm
<b>Horizontal angle of view</b>	74,2° - 30°
<b>Iris control</b>	DC
<b>MOD (Minimum object distance)</b>	0,15 m
<b>Focus range</b>	0.15m ~∞
<b>Filter screw size</b>	not available
<b>Alarm inputs</b>	-
<b>Illumination</b>	20x IR LED's 850nm. Due to an integrated light sensor the LED illumination will be switched ON/OFF, depending on environmental illumination conditions.
<b>Illumination range</b>	approx. 20m (at a good light reflexion and 40% Videosignal)
<b>Motion Detection Function</b>	no
<b>Day / Night Switching</b>	Automatic (camera controlled)
<b>Internal adjustments</b>	Automatic Gain Control (AGC), Back Light Compensation (BLC), Shutter Low Speed (DSS), Day / Night, Flickerless ON / OFF
<b>External connections</b>	Video (BNC), Power input
<b>Serial interfaces</b>	no
<b>Heater</b>	no
<b>Protection rating</b>	IP65, at installation according to the manual
<b>Supply voltage</b>	12VDC
<b>Power consumption</b>	6watts
<b>Vandalism resistant</b>	yes
<b>Colour (bubble)</b>	tinted
<b>Mounting</b>	For wall and drop ceiling mount
<b>Camera adjustment</b>	3-axis camera adjustment
<b>Camera fixing</b>	dome
<b>Camera mount</b>	See drawing
<b>Mounting</b>	surface mount, wall mount

# VKCD-1326/IR

(Continuation Specifications)

<b>Housing</b>	Outdoor
<b>Housing material</b>	Metal
<b>Colour (housing)</b>	Pantone Cool Gray 1C
<b>Dimensions (HxWxD)</b>	See drawing
<b>Weight</b>	880g
<b>Parts supplied</b>	Mounting screw kit, Service monitor cable, Manual
<b>Certificates</b>	CE

## Optional accessories

<b>70495</b>	<b>VT-PS12DC-7</b>	Plugable PSU w. Cont. & UK Mains plug-in 100-240VAC/12VDC-1.25A, Regulated
<b>74151</b>	<b>VDOME/WB2</b>	Wall Mount Kit for Vandalism Resistant Dome Cameras SM/VF Series
<b>70535</b>	<b>VT-PS12DC-8</b>	Plug-in Power Supply Unit 100-240VAC 12VDC (1.0Amp), Regulated, with DC Plug
<b>77773</b>	<b>VT-PS12DCDT1</b>	PSU 12VDC/1.0A, Regulated, Desktop Version, 1.8m Cables each w. open ends
<b>88149</b>	<b>3/4"- M25X1.5</b>	Thread Adapter 3/4"- Conduit Connection M25x1.5mm for Dome Surface Mount Housing

# VKCD-1326/IR

Home | Security | Dome Cameras | Fixed

## Technical drawing

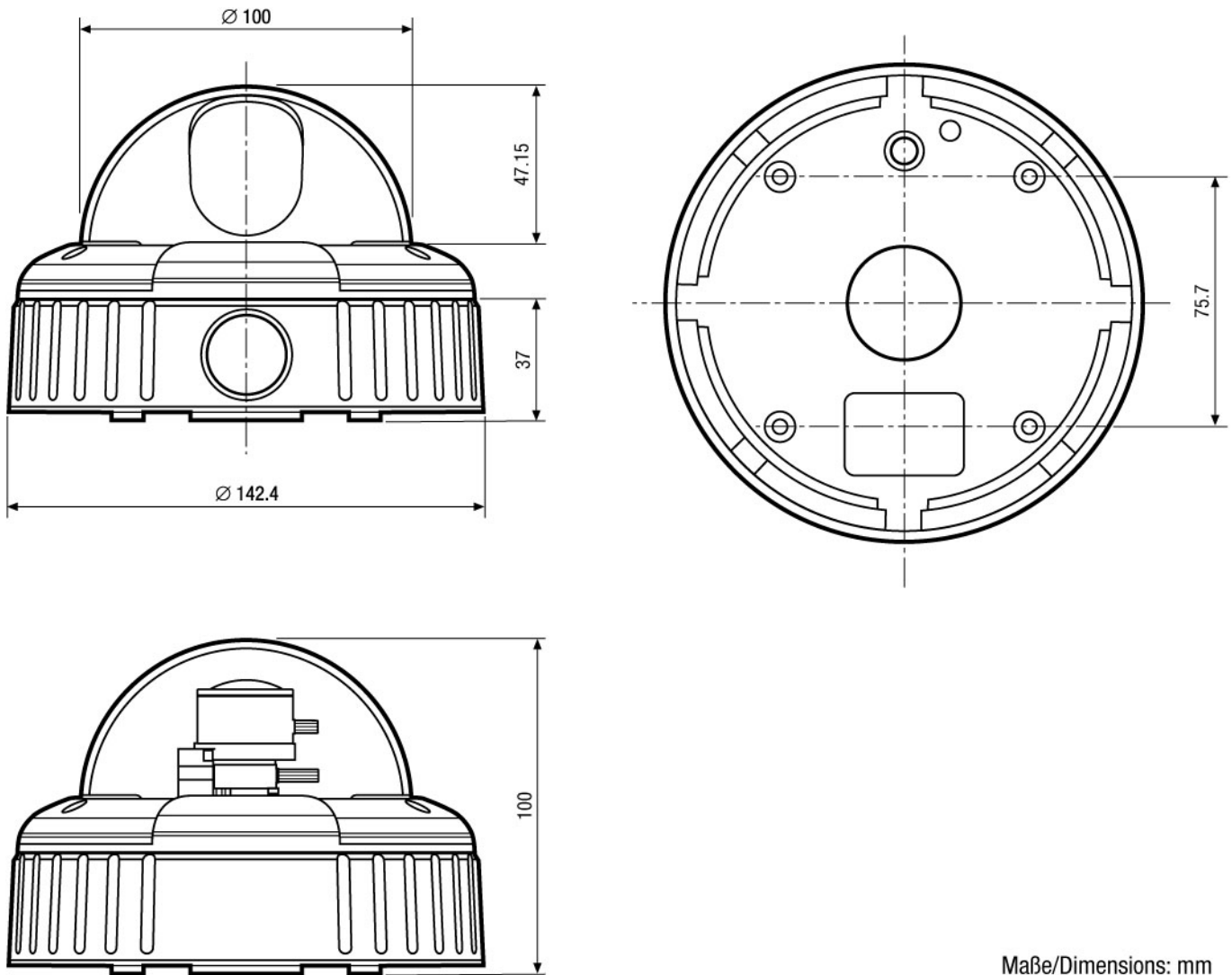

Maße/Dimensions: mm

SLD Security & Communications  
The Old Forge, Ockham Lane, Ockham, Surrey GU236PH England  
Phone +44.1483225633 · Fax +44.1483225634  
sales@sld.co.uk · www.sld.co.uk

