

Video Security



VHM/ECLKA

Weatherproof Housing (330mm) with Heater, Thermostat, CBD, RAL7032, 230VAC

Art-No. 79404



Features

Camera Weatherprotection

Housing Body Length 330mm

Fold-down Housing Body

4 Levels of Camera Height Adjustment

Insulated Camera Mounting

Integrated Connection Board

3 Cable Entries

Screen Heater 230VAC Included

Viewing Screen with "Clear-Shield" Technology

Incorporated Carrier Handle

Protection Rating IP66

Housing Surface RAL7032

Specifications

Maximum installation length	330 mm
Length for power supply	NE-112 (1 output): 85 mm; NE-112/2 (2 outputs): 110 mm
Cable entries	3x M16x1.5mm
Window screen	Coated with "Clear Shield" Technology. With this technology the glass corrosion, caused by environmental pollution, is avoided and screen cleaning cycles will be extended. The coating is UV light resistant, colour neutral and it causes no F-stop loss.
Window heater	110-265V / approx. 9watts
Thermostat	On: +16°C, Off: +20°C
Sunshield	Yes
Housing	Aluminium w. plastic end caps
Colour	RAL 7032
Protection rating	IP 66
Parts supplied	Screw set, thermostat switch, screw terminal
Dimensions (HxWxD)	See drawing
Weight	2.8 kg

Accessories

73064 / WD-16/MK	Wall Mount with Swivel Head for VHB/VHM Weatherproof Housings, RAL7032
71601 / VHM/H24	VHM Window Heater 12-30V (PTC Element)
79491 / NE-112/AC24V	Power Supply Unit 230VAC/24VAC (600mA) for VHM Housing
79423 / NE-112/2	Power Supply Unit 230VAC/12VDC (600mA), Regulated, 24VAC (1000mA) f. VHM Housing
79364 / NE-112	Power Supply Unit 230VAC/12VDC (600mA) for VHM Housing, Regulated
79623 / VHM/PC-1	Plug-in shield for VHM/EC&ST Housing Series, 330mm
70457 / AK-3	Camera Connection box, 230VAC Input 24VAC-100W, 12VDC-1A Output

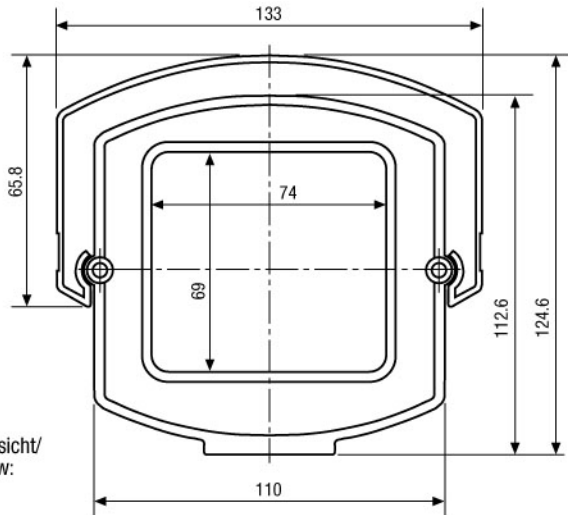

Vorderansicht/
Front view:

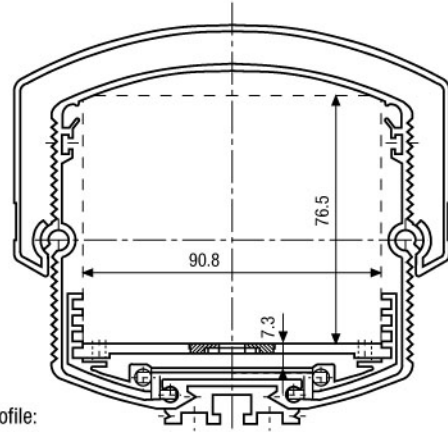

Profil/Profile:

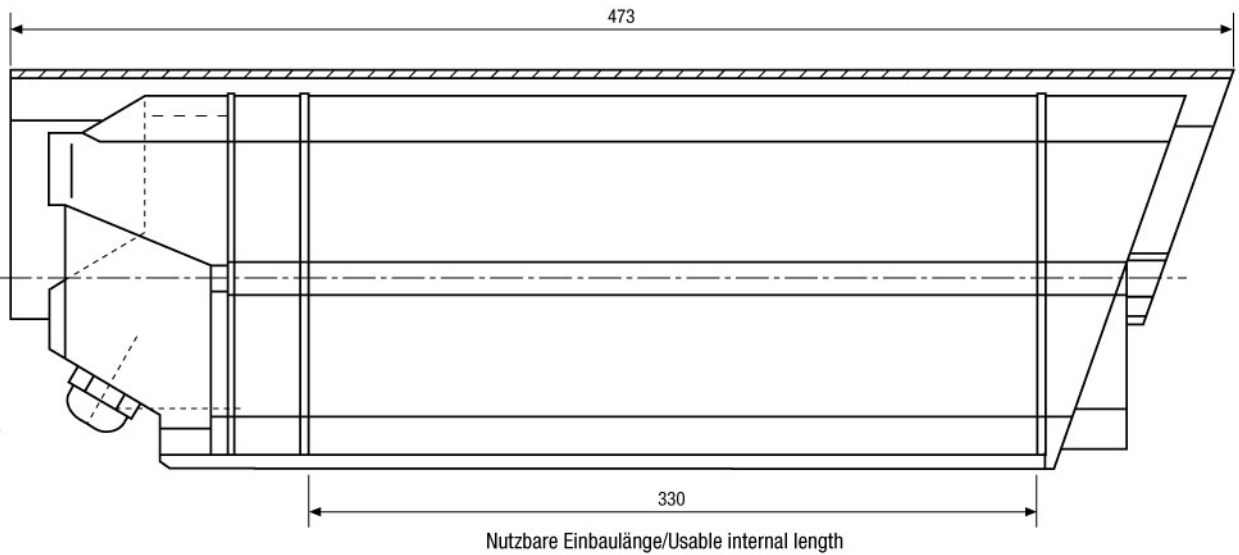

Seitenansicht/
Side view:

Nutzbare Einbaulänge/Usable internal length

Maße/Dimensions: mm